

Communication Path Options – Basics - Utility CIS <-> Meter - example

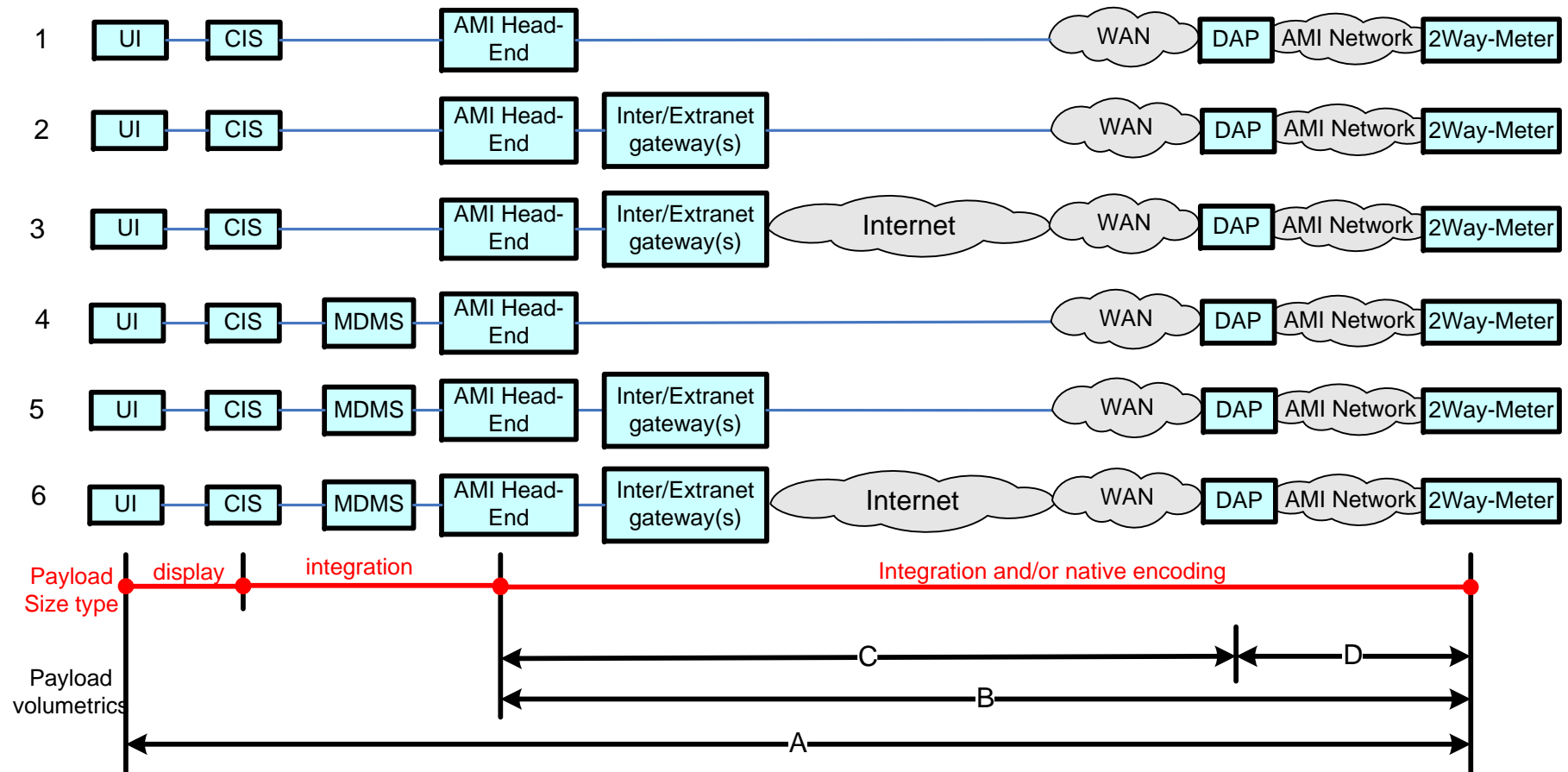

Notes:

- 1) Business volumetric requirements are being documented for the application payloads between specific actors for specific communications paths. Typically it is easier to document these volumetric requirements for the dataflows (ref boundary points above), in the following order: A, C, B or D.
- 2) Most volumetrics for dataflows for the same payload, **MUST NOT** be relaxed more than their parents volumetric requirements. E.G.: a) the latency for dataflow B, **MUST** be < A's; b) C + D latency **MUST** be < B's; **HOWEVER**, the total amount of payloads per dataflow will diminish as one traverses towards a singular endpoint, e.g. specific payload qty for CIS & HeadEnd probably will be equal, HeadEnd = sum of DAPs; a specific DAP = sum of meters that the specific DAP has been designed/deployed to handle.
- 3) For the CIS <-> Meter comm paths, several payloads will concurrently traverse, each with different business volumetric reqmts. E.G.: a) on-demand meter reads, b) meter read of multiple interval data time blocks, c) service switch ops & status, d) demand resets, e) meter last-gasp, f) and this same common path used to pass HAN, prepay, load control, type messages to HAN devices

CIS / Billing - Utility <-> 2Way-Meter (no ESI) Communication Path Options

Path
option

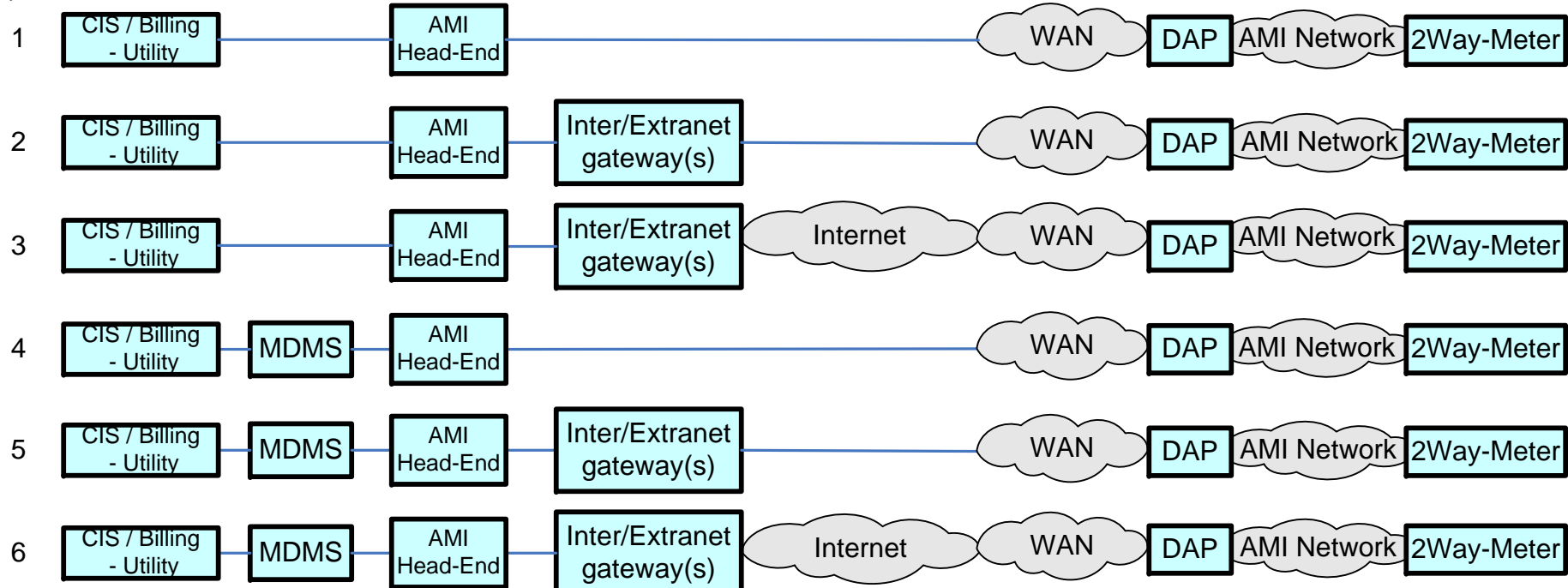

CIS / Billing - Utility <-> 2Way-Meter (via ESI) Communication Path Options

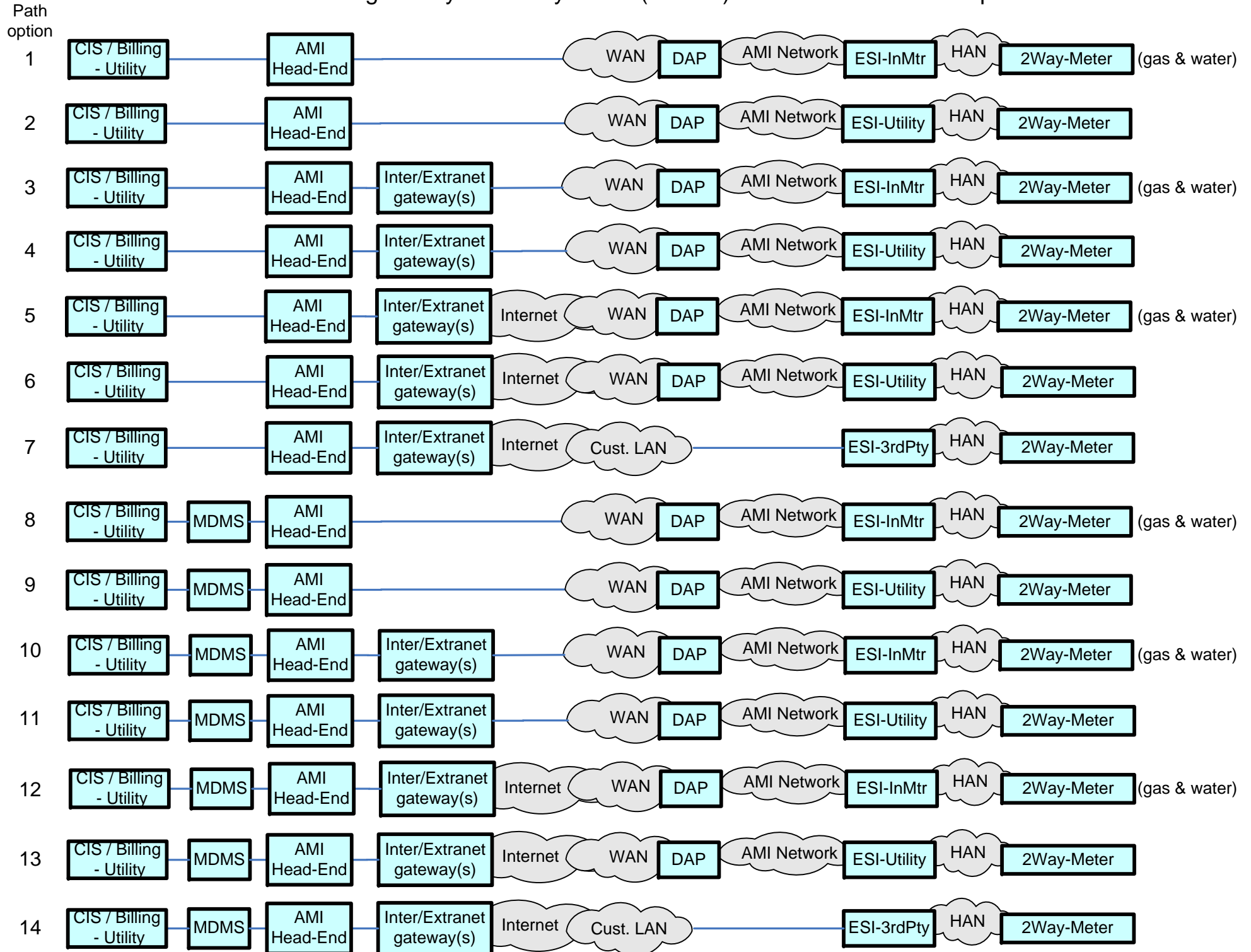

CIS / Billing - Utility <-> HAN Device Communication Path Options

Path
option

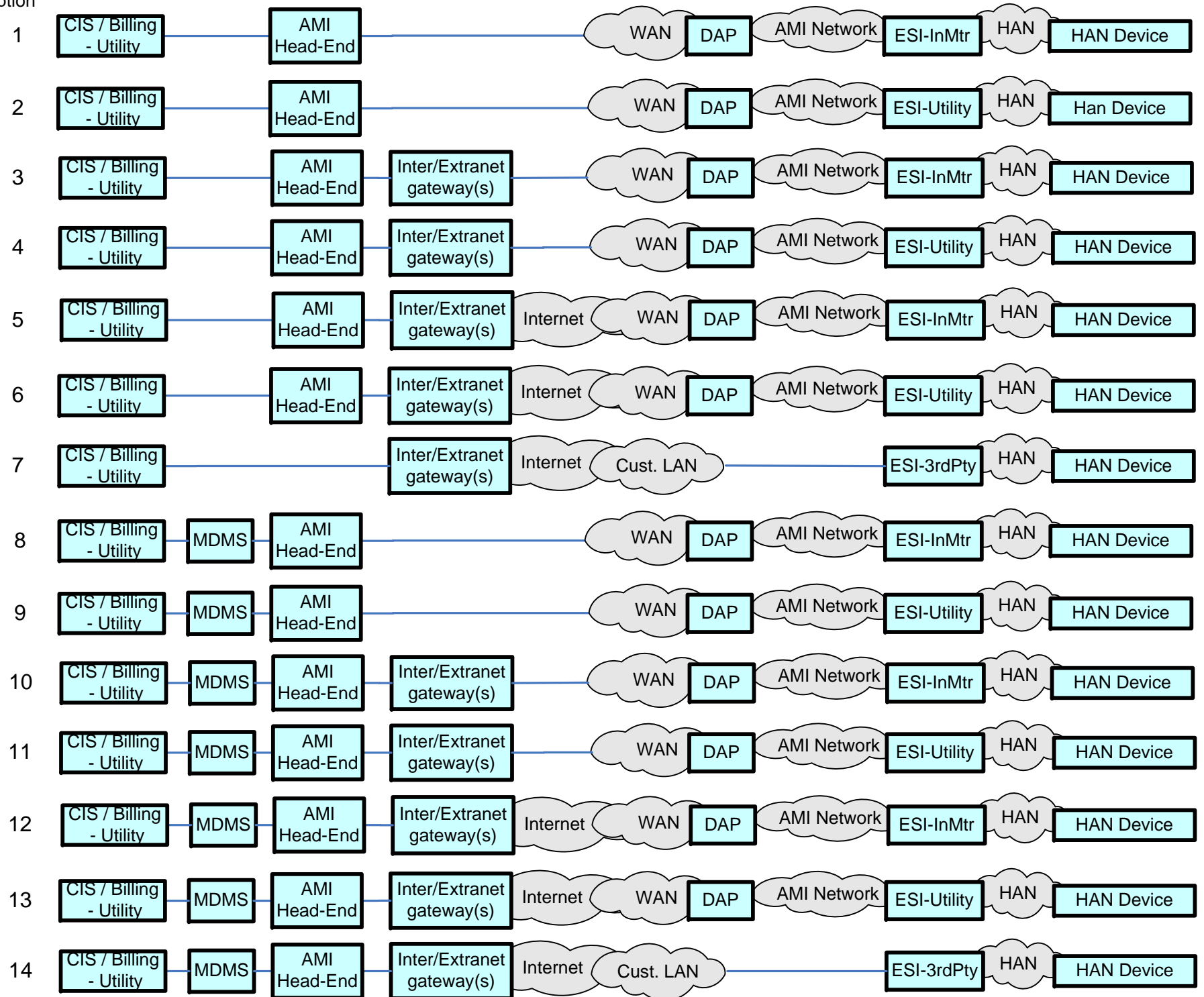

IPD or Cust. EMS <-> 2Way-Meter Communication Path Options

Path option

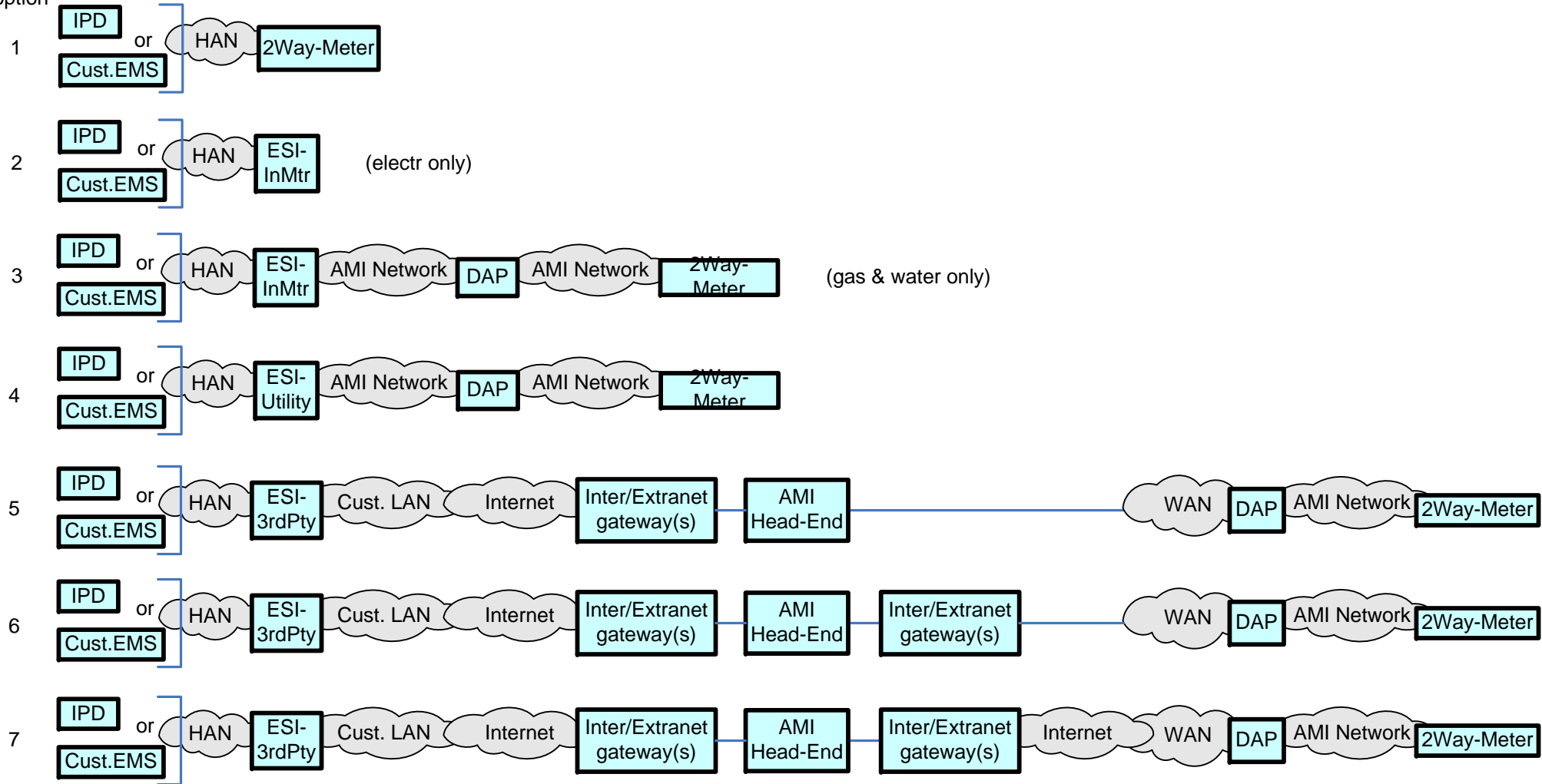

Path
option

Utility DSM or LMS <-> 2Way-Meter (electr) & HAN Devices - Communication Path Options

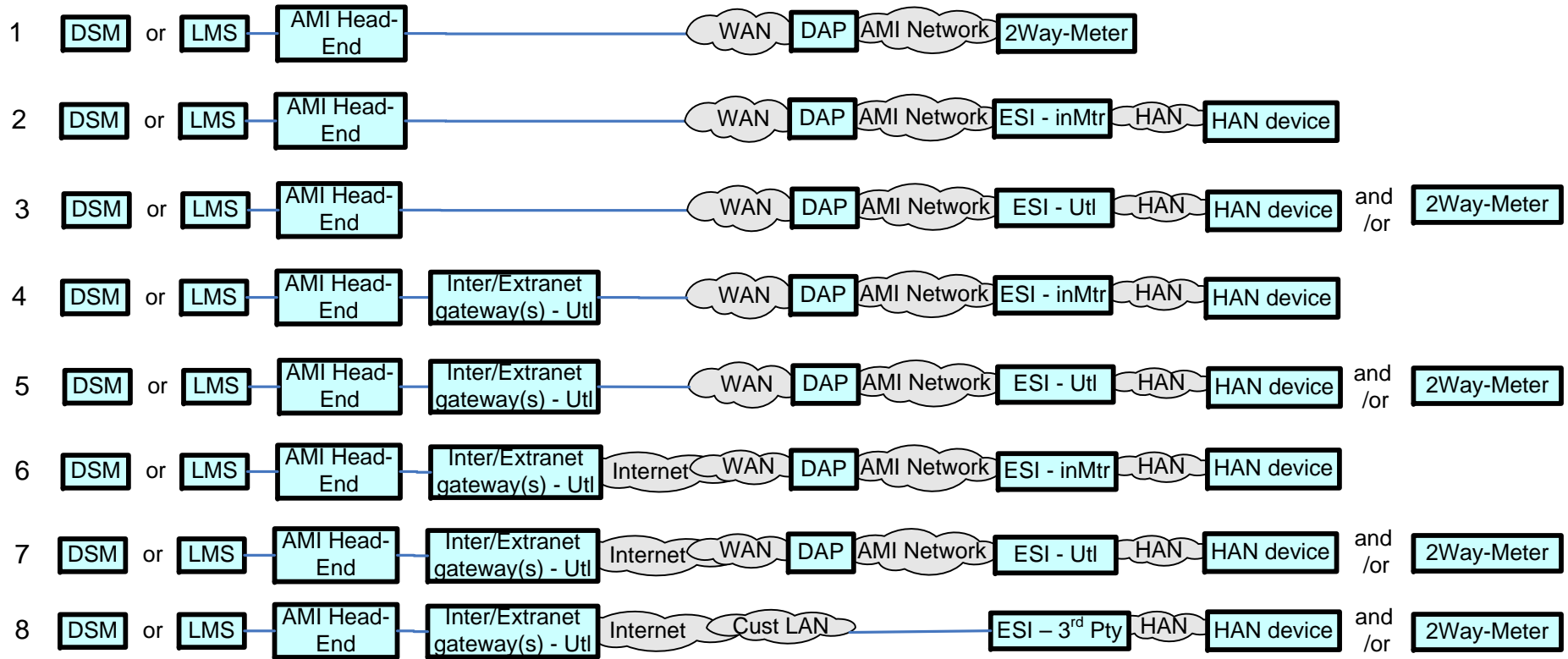

CIS / Billing - REPi <-> 2Way-Meters & HAN Devices - Communication Path Options

Path option

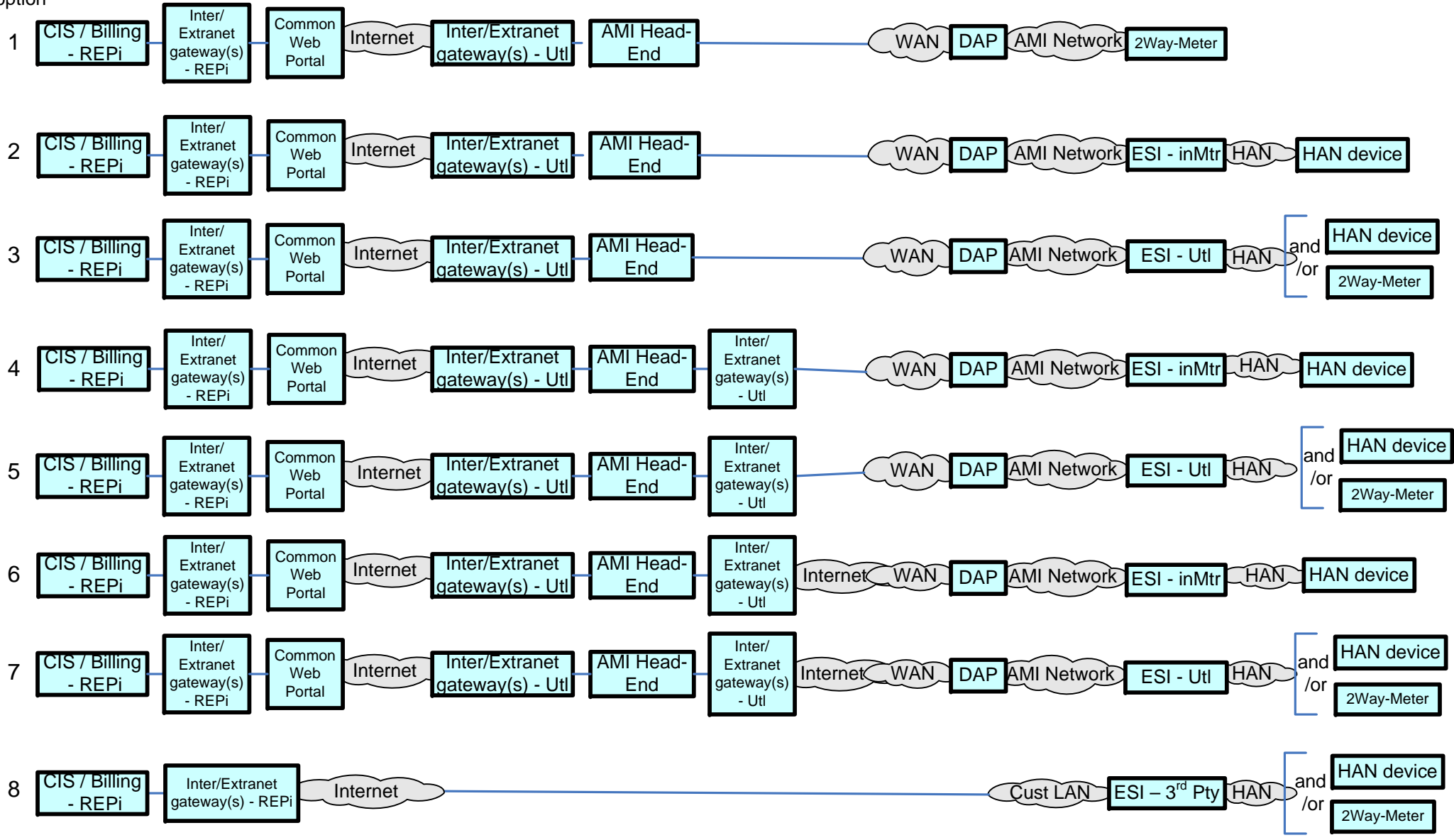

Path option

REPi DSM or LMS <-> 2Way-Meters & HAN Devices - Communication Path Options

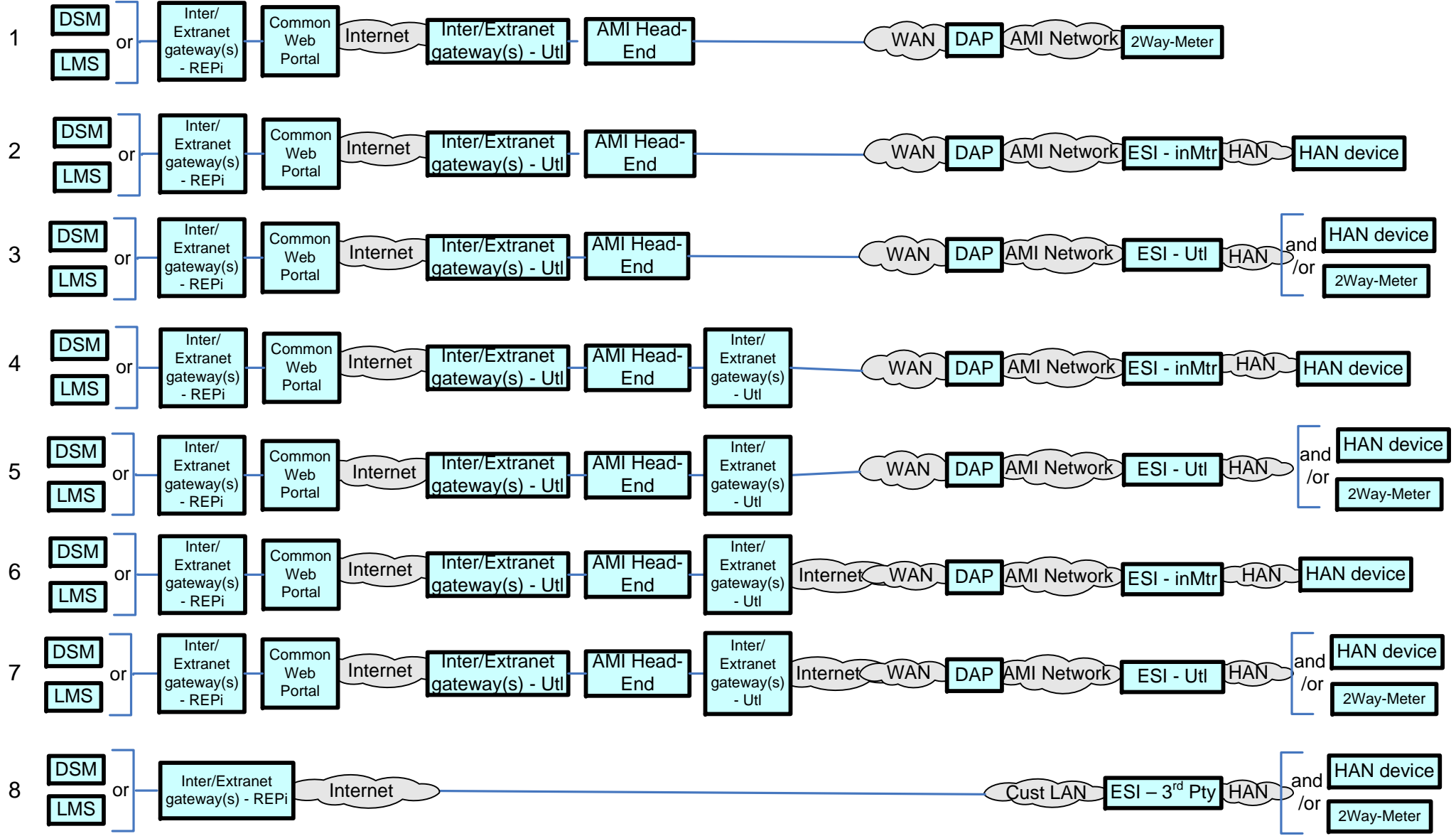

Cust <-> Web Portal - Communication Path Options

Path option

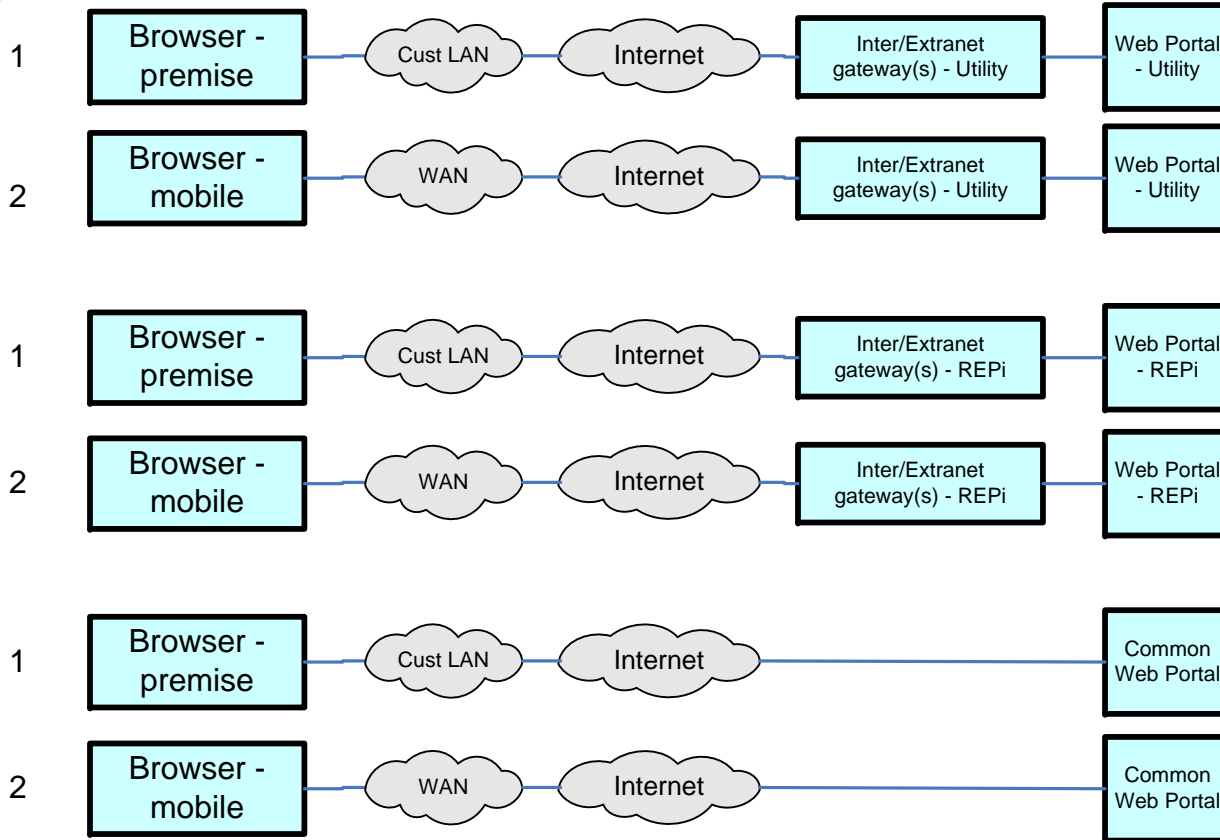

Web Portal <-> ODS - Communication Path Options

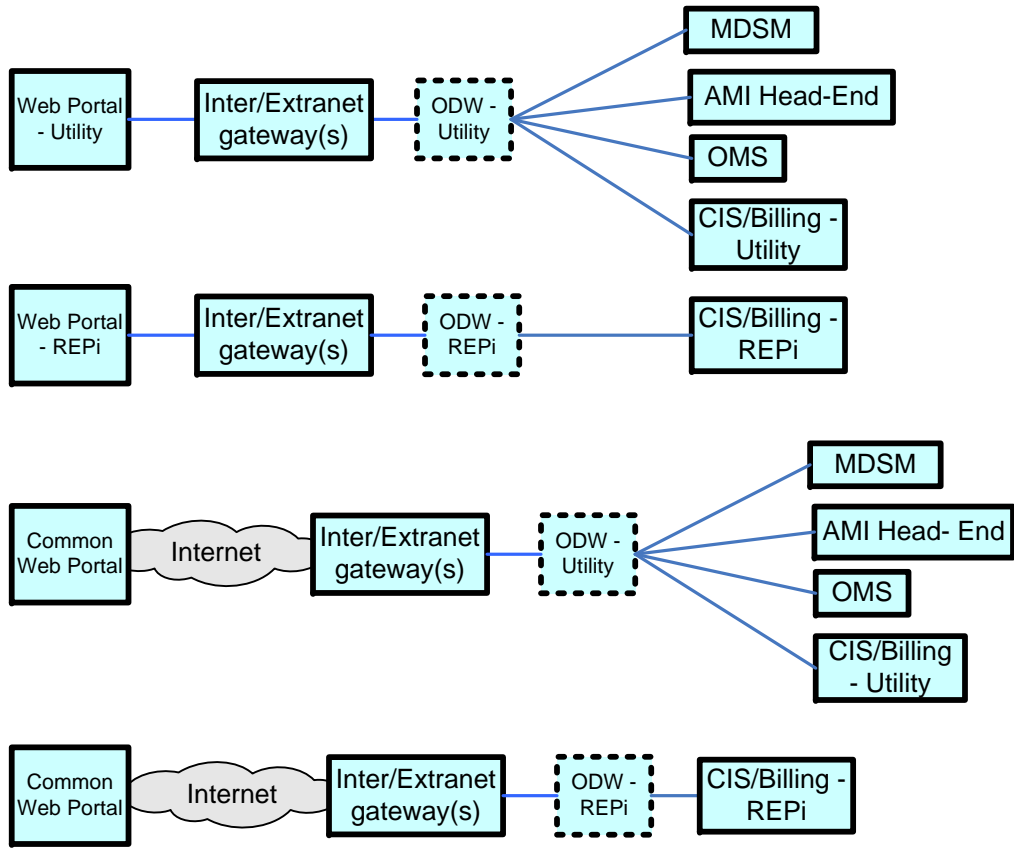

Path
option

DMS <-> DA Feeder Devices - Communication Path Options

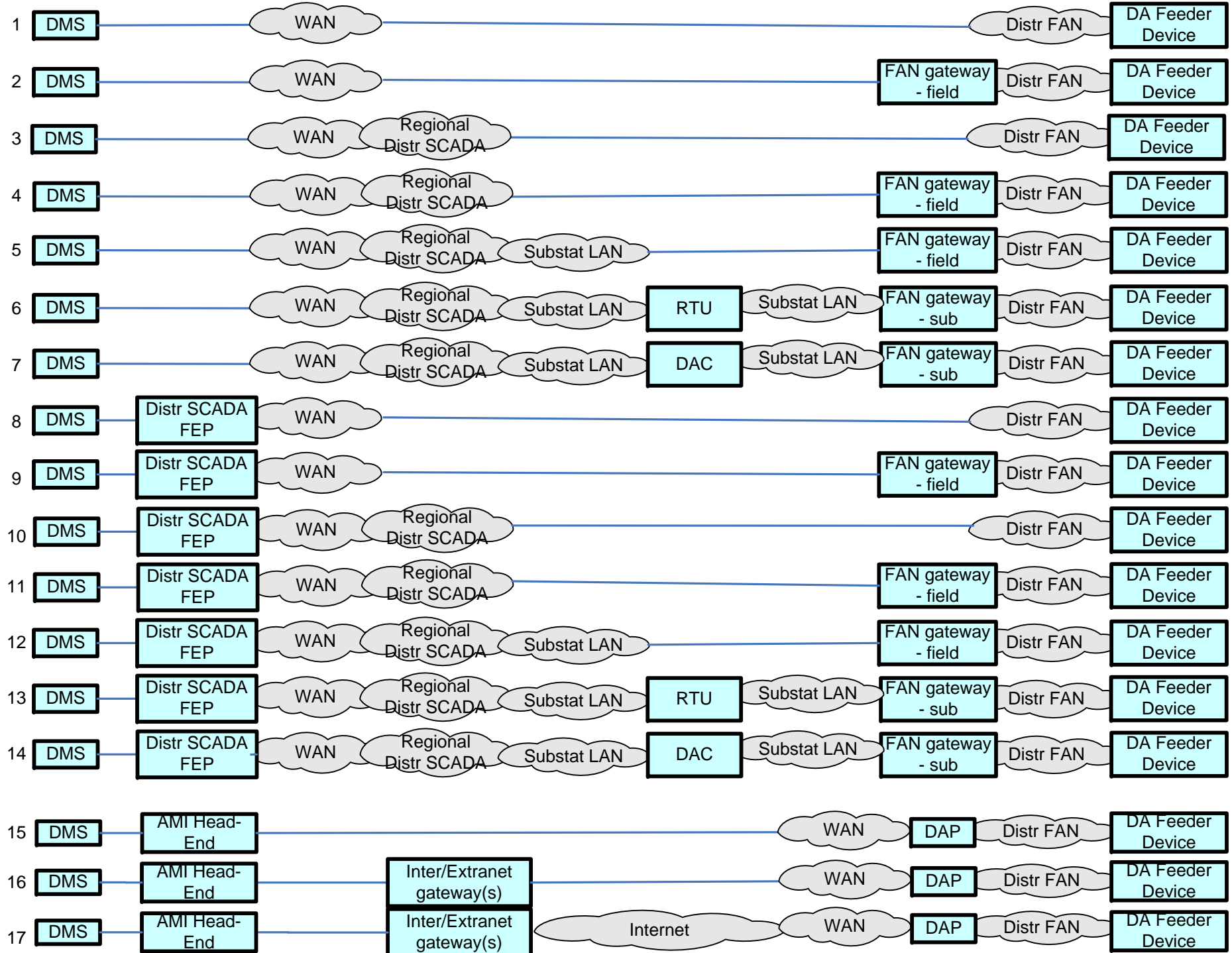

DMS <-> DA Substation Devices - Communication Path Options

